



WE LIGHT YOU UP

Au-lite[®]

Au-lite Lighting Inc.

No.200, Sec. 1, Fulin Rd., Qionglin Township, Hsinchu County 30746, Taiwan
Tel: 886-3-5933636 Fax: 886-3-5933737
<http://www.au-lite.com.tw>
E-mail: au.lite@msa.hinet.net



Copyright © 2009 Au-lite Lighting Inc. All Rights reserved.

Au-lite[®]

A black and white photograph of a young child with light-colored hair, looking out of a car window. The child's hand is resting on the window frame. The image is partially overlaid with a teal-colored rectangular area on the left side. Inside this teal area, the text "Beyond Lighting" is written in a white, sans-serif font. The background outside the car is blurred, showing what appears to be a parking lot or a similar outdoor setting.

Beyond
Lighting

Company Profile

Au-lite Lighting Inc. was established since 1984 and has been engaged in manufacturing auto bulbs of various different models. It is a specialized auto-bulbs firm with ISO 9001 certification and supplies "ROHS" qualified bulbs. Many of our products have won E-Mark and DOT certification. Our sales channel includes Taiwan, Europe, Russia, Africa, South-East Asia, Japan, Australia, USA and Central and South America.

Mr. Eric C Chen, Chairman of the Board and Founder of Au-lite Lighting Inc. believes that product quality and reliability are the core competitiveness of the company and is the foundation of sustained operation. With such belief and insistence, the company has won long term and firm support from large number of customers. In market development, the company has accumulated enormous experience, as we are not only equipped with specialized marketing personnel and sophisticated systems, we have strong R&D as well as QC background that enable us to place our products to the most competitive international market and established a firm stand.

We are proud of our quality, but we are not satisfied yet. In the future, further quality enhancements and zero-complaint from customers are still what we are endeavoring for. Our vision is to be the market guidepost of auto lighting. Your niche is thoroughly guarded by Au-lite Lighting Inc.



Quality Control Lab

A whole set of checking and measuring equipments to ensure the highest quality from development right through to production.



High Frequency Plastic Welding Machine



Digital Measuring Projector



Lighting Tester



Vibration Simulator System



Car Bulb Shock Tester



Programmable Temp. & Humi. Chamber



Spectrophotometer Integrating Sphere



Salt Spray Tester



Certificat

Certificate

N° 2011/41277.2

AFNOR Certification certifies that the management system implemented by:
AFNOR Certification certifie que le système de management mis en place par :

AU-LITE LIGHTING INC.

for the following activities:
pour les activités suivantes :

DESIGN, ASSEMBLY AND SALE OF LAMPS/BULBS.

has been assessed and found to meet the requirements of:
a été évalué et jugé conforme aux exigences requises par :

ISO 9001 : 2015

and is developed on the following locations:
est déployé sur les sites suivants :

NO. 200, SEC. 1, FULIN RD., QIONGLIN TOWNSHIP, HSINCHU COUNTY 30746, TAIWAN (R.O.C.)

This certificate is valid from (year/month/day)
Ce certificat est valable à compter du (année/mois/jour)

2017-08-31

until
jusqu'au

2020-08-30





Franck LEBEUGLE
Managing Director of AFNOR Certification
Directeur Général d'AFNOR Certification



Scan this QR code to check the validity of the certificate

11 rue François de Piossane - 80571 La Plaine Saint-Denis Cedex - France - T. +33 (0)1 41 52 80 00 - F. +33 (0)1 40 17 30 03
SAS au capital de 10 107 000 € - 476 076 003 RCS Nanterre - www.afnor.org



























Types and Uses

Low beam/full beam



Front indicator



Fog light/DRL



Dashboard light



Parking/marker light



Trunk light



Side indicator



Stop lights



Rear indicator



Taillight



Rear indicator



Reversing light



Interior light



Number plate light



Halogen Bulbs for Automobiles

Figure	Type	Code	Spec.	Luminous Flux Lm	Life Hours	Base	Certification
1	H1	AH101	12V 55W	1550 ± 15%	400	P14.5S	DOT & E
	H1	AH102	12V 100W	2300 ± 15%	100	P14.5S	
	H1	AH103	24V 70W	1900 ± 15%	300	P14.5S	DOT & E
	H1	AH104	24V 100W	2300 ± 15%	100	P14.5S	
2	H2	AH201	12V 55W	1800 ± 15%	250	X511	
	H2	AH202	24V 70W	2150 ± 15%	250	X511	
3	H3	AH301	12V 55W	1450 ± 15%	500	PK22S	DOT & E
	H3	AH302	12V 100W	2000 ± 15%	100	PK22S	
	H3	AH303	24V 70W	1750 ± 15%	300	PK22S	DOT & E
	H3	AH304	24V 100W	2400 ± 15%	100	PK22S	
4	H3C	AHC01	12V 55W	1450 ± 15%	300	PK22D	
	H3C	AHC02	12V 100W	2000 ± 15%	100	PK22D	
	H3C	AHC03	24V 70W	1750 ± 15%	250	PK22D	
	H3C	AHC04	24V 100W	2400 ± 15%	100	PK22D	
5	H4	AH401	12V 60/55W	1650 ± 15% / 1000 ± 15%	150/320	P43T or P45T	DOT & E
	H4	AH402	12V 100/90W	2550 ± 15% / 1820 ± 15%	100/200	P43T or P45T	
	H4	AH403	24V 75/70W	1900 ± 15% / 1200 ± 15%	150/300	P43T or P45T	DOT & E
	H4	AH404	24V 100/90W	2550 ± 15% / 1820 ± 15%	100/200	P43T or P45T	
6	H7	AH701	12V 55W	1500 ± 10%	400	PX26D	DOT & E
	H7	AH702	12V 100W	2200 ± 10%	100	PX26D	
	H7	AH703	24V 70W	1750 ± 10%	300	PX26D	DOT & E
	H7	AH704	24V 100W	2200 ± 10%	100	PX26D	
7	H8	AH801	12V 35W	800 ± 15%	400	PGJ19-1	DOT & E
8	H9	AH901	12V 65W	2100 ± 10%	250	PGJ19-5	DOT & E
9	H10	AH1001	12V 42W	850 ± 15%	400	PY20D	
10	H11	AH1101	12V 55W	1350 ± 10%	500	PGJ19-2	DOT & E
11	H12	AH1201	12V 53W	1050 ± 15%	400	PZ20D	
12	H13	9008	12V 60/55W	1700 ± 15% / 1100 ± 15%	150/320	P26.4T	DOT & E
13	H15	AH1501	12V 15/55W	260 ± 10% / 1350 ± 10%	500/300	PGJ23t-1	
14	H16	AH1601	12V 19W	500 ± 10% / -15%	300	PGJY19t-3	DOT & E
15	H17	AH1701	12V 35/35W	900 ± 10% / 600 ± 10%	150/320	PU43t-4	DOT & E
16	H18	AH1801	12V 65W	1700 ± 8%	400	PY26d-1	DOT & E
17	H19	AH1901	12V 60/55W	1750 ± 10% / 1200 ± 10%	150/320	PU43t-3	DOT & E

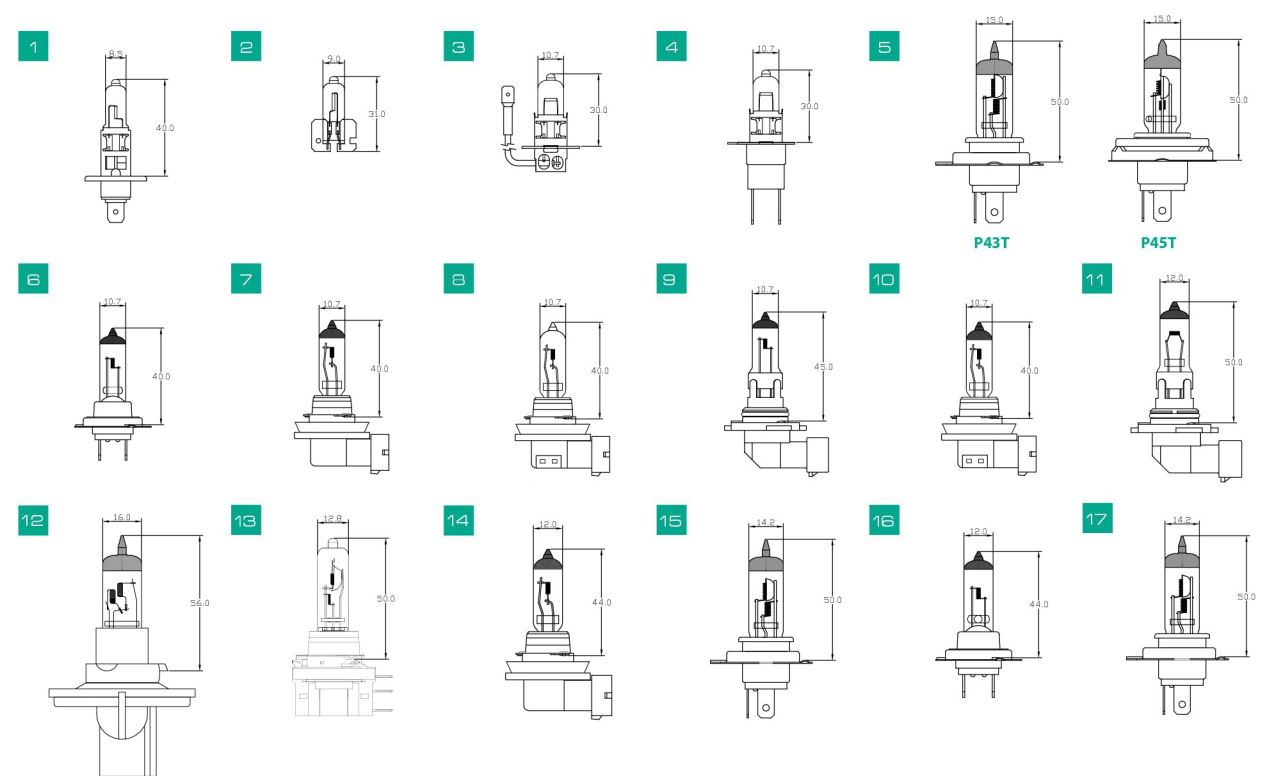

Halogen Bulbs for Automobiles

Figure	Type	Code	Spec.	Luminous Flux Lm	Life Hours	Base	Certification
1	HB1	9004	12V 65/45W	1200 ± 15% / 700 ± 15%	150/320	P29T	DOT
	HB1	9004	12V 100/80W	1600 ± 15% / 1200 ± 15%	100/200	P29T	
2	HB3	9005	12V 65W	1860 ± 12%	250	P20D	DOT
	HB3	9005	12V 100W	2200 ± 12%	150	P20D	
3	HB4	9006	12V 55W	1095 ± 15%	450	P22D	DOT
	HB4	9006	12V 80W	1900 ± 15%	250	P22D	
4	HB5	9007	12V 65/55W	1350 ± 15% / 1000 ± 15%	150/320	PX29T	DOT
	HB5	9007	12V 100/80W	1600 ± 15% / 1400 ± 15%	100/200	PX29T	
5	HIR1	9011	12V 65W	2500 ± 15%	150	PX20d	DOT & E
6	HIR2	9012	12V 55W	1875 ± 15%	320	PX22d	DOT & E

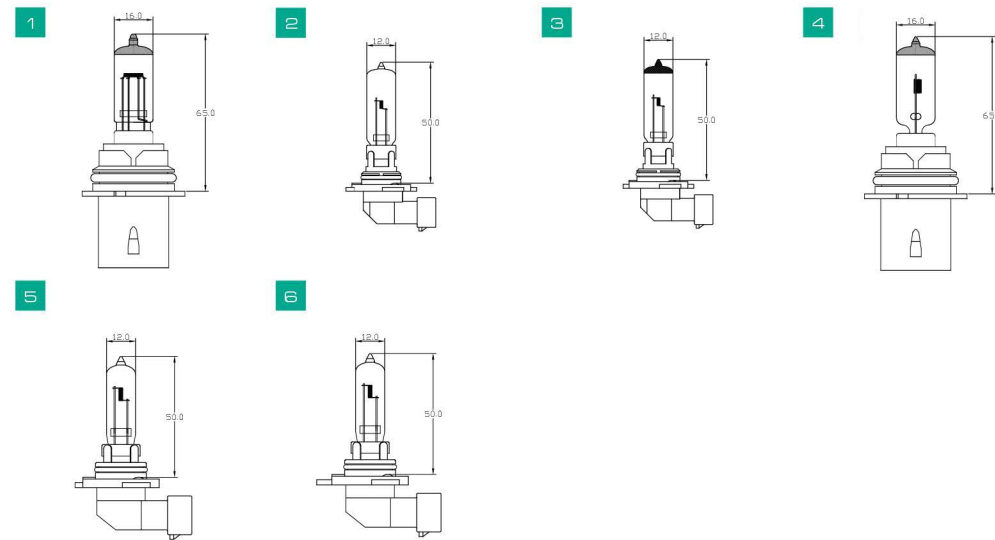

Halogen Bulbs for Automobiles

Figure	Type	Code	Spec.	Luminous Flux Lm	Life Hours	Base	Certification
1	880	AH880	12V 27W	560 ± 15%	300	Axial	DOT & E
	893	AH893	12V 37.5W	980 ± 15%	300	Axial	
2	881	AH881	12V 27W	560 ± 15%	300	Right-Angle	DOT & E
	896	AH896	12V 37.5W	980 ± 15%	300	Right-Angle	
3	884	AH884	12V 27W	560 ± 15%	300	Axial	
	885	AH885	12V 50W	1300 ± 15%	300	Axial	
4	886	AH886	12V 50W	1300 ± 15%	300	Right-Angle	
5	889	AH889	12V 27W	560 ± 15%	300	Right-Angle	
6	890	AH890	12V 27W	560 ± 15%	300	Axial	

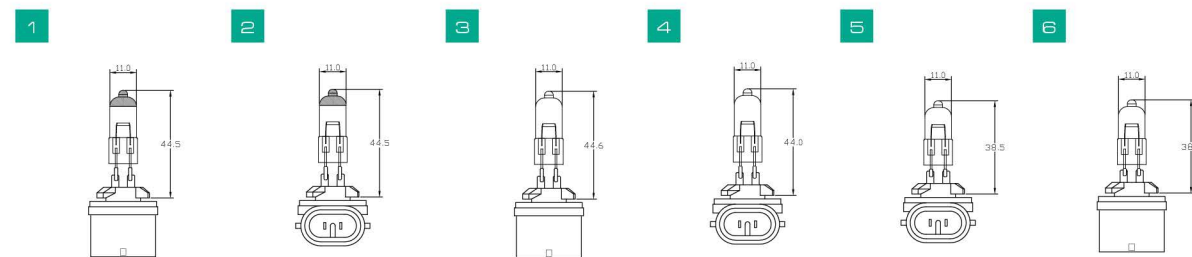

Compact Halogen Bulbs

Figure	Type	Code	Spec.	Luminous Flux Lm	Life Hours	Base
1	HPC16W	HPC1601	12V 16W	300 ± 15%	400	PU20d-1
2	HPC19W	HPC1901	12V 19W	350 ± 15%	400	PU20d-3
3	HPC24W	HPC2401	12V 24W	500+10% / -15%	300	PU20d-6
4	P13W	P1301	12V 13W	250+15% / -20%	400	PG18.5d-1
5	PS19W	PS1901	12V 19W	350 ± 15%	400	PG20-1
6	PS24W	PS2401	12V 24W	500+10% / -20%	300	PG20-3
7	PSX24W	PSX2401	12V 24W	500+10% / -15%	300	PG20-7
8	PSX26W	PSX2601	12V 26W	500 ± 10%	300	PG18.5d-3
9	PSY19W	PSY1901	12V 19W	215 ± 20%	300	PG20-2
10	PSY24W	PSY2401	12V 24W	300+15% / -25%	300	PG20-4

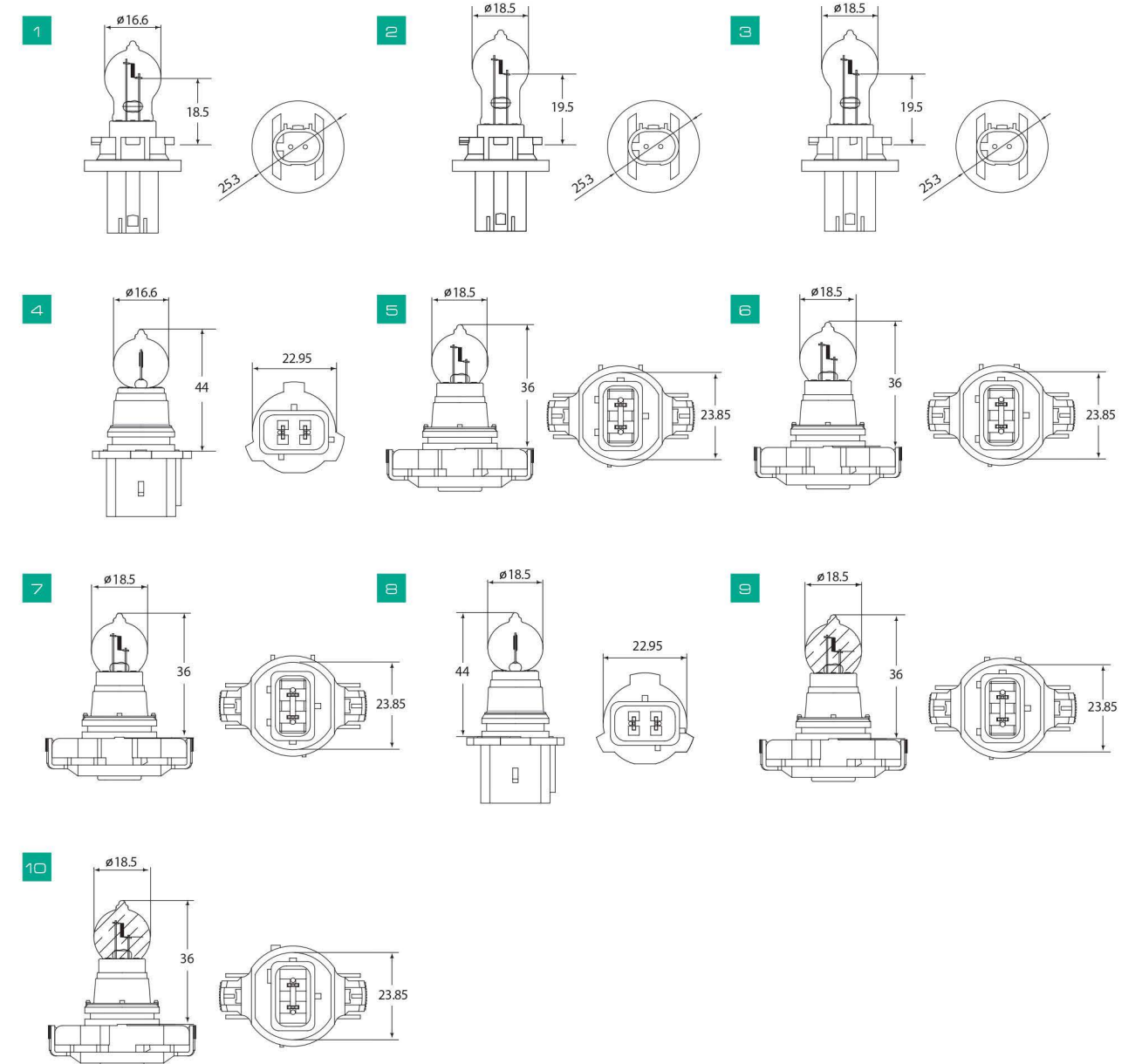

Miniature Halogen Bulbs

Figure	Type	Code	Spec.	Luminous Flux Lm	Life Hours	Base	Certification
1	JM	JM001	12V 5W	60±20%	300	BA9S	
	JM	JM002	12V 10W	150±20%	300	BA9S	
	JM	JM003	12V 20W	300±20%	300	BA9S	
2	H6W	HS003	12V 6W	125±12%	500	BAX9S	E
3	H21W	HS004	12V 21W	600±12%	400	BAY9S	E
	H21W	HS005	24V 21W	600±15%	300	BAY9S	E
4	795	AH501	12V 50W	1350±15%	200	BA15S	
5	795X	AH502	12V 50W	1350±15%	200	BA15S	
6	JC	JC001	12V 10W	150±15%	300	G4	
	JC	JC002	12V 20W	350±15%	300	G5.3	
	JC	JC003	12V 35W	600±15%	300	G6.35	

Halogen Bulbs for Motorcycle

Figure	Type	Code	Spec.	Luminous Flux Lm	Life Hours	Base	Certification
7	H6M	AH601	12V 18/18W	380±15% / 340±15%	150/300	P15d-30 (HL)	
8	H6M	AH602	12V 25/25W	600±15% / 540±15%	150/300	P15d-25-1 (HS)	
9	H6M	AH603	12V 30/30W	700±15% / 650±15%	150/300	P15d-25-3 (HV)	
10	H6M	AH604	12V 35/35W	850±15% / 780±15%	150/300	BA20d	
11	HS1	AHX01	12V 35/35W	825±15% / 525±15%	150/320	PX43T	E
12	HS2	HS201	6V 15W	320±15%	200	PX13.5S	
	HS2	HS202	12V 15W	320±15%	200	PX13.5S	
13	S1	AS101	12V 25/25W	435±20% / 315±20%	85/170	BA20d	
	S2	AS201	12V 35/35W	650±20% / 465±20%	85/170	BA20d	E
14	HR2	HR201	12V 45/40W	1050±15% / 600±15%	150/300	P45T	E

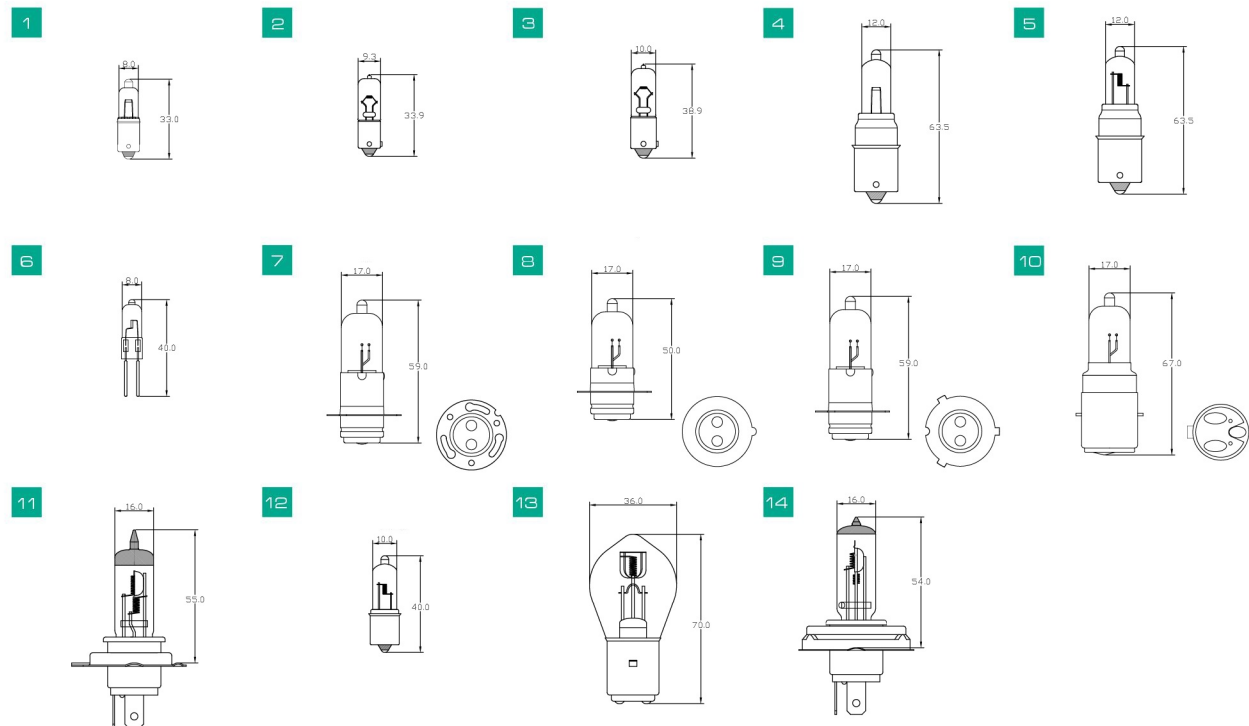

Miniature Bulbs For Automobiles

Figure	ECE Type	Code	Spec.	Luminous Flux Lm	Life Hours	Base	Certification
1	P21/5W	AG001	S25 12V 21/5W	440±15% / 35±20%	160/1600	BAY15D	E
	P21/5W	AG002	S25 24V 21/5W	440±15% / 40±20%	160/1600	BAY15D	E
2	P21W	AG003	S25 12V 21W	460±15%	160	BA15S	E
	P21W	AG004	S25 24V 21W	460±15%	160	BA15S	E
	PY21W	AG005	S25 12V 21W	280±20%	300	BAU15S	E
3	R5W	AG006	G18 12V 5W	50±20%	300	BA15S	E
	R10W	AG007	G18 12V 10W	125±20%	300	BA15S	E
	R5W	AG008	G18 24V 5W	50±20%	225	BA15S	E
	R10W	AG009	G18 24V 10W	125±20%	225	BA15S	E
	RY10W	AG010	G18 12V 10W	75±20%	300	BAU15S	E
			AG011	T16 12V 5W	50±20%	300	BA15S
4		AG012	T16 12V 10W	125±20%	300	BA15S	
		AG013	T16 24V 5W	50±20%	250	BA15S	
		AG014	T16 24V 10W	125±20%	250	BA15S	
			AG015	T10 12V 3W	22±30%	1500	W2.1x9.5d
5	W3W	AG015	T10 12V 3W	22±30%	1500	W2.1x9.5d	E
	W5W	AG016	T10 12V 5W	50±20%	500	W2.1x9.5d	E
	W3W	AG017	T10 24V 3W	22±30%	1100	W2.1x9.5d	E
6	W5W	AG018	T10 24V 5W	50±20%	350	W2.1x9.5d	E
		AG019	T13 12V 10W	125±20%	300	W2.1x9.5d	
7		AG020	T15 12V 18W	210±20%	1000	W2.1x9.5d	
8		AG021	T5 12V 1.2W	6.2±20%	1000	W2.0x4.6d	
		AG022	T5 12V 2.3W	12.6±20%	1000	W2.0x4.6d	
		AG023	T5 24V 1.2W	5.2±20%	1000	W2.0x4.6d	
		AG024	T5 24V 2W	9.75±23%	1000	W2.0x4.6d	
9	W21W	AG025	T20 12V 21W	460±15%	160	W3x16d	E
10	W21/5W	AG026	T20 12V 21/5W	440±15% / 35±20%	160/1600	W3x16d	E
11	P27W	AG027	3156 12V 32CP	475±15%	160	W2.5x16d	E
12	P27/7W	AG028	3157 12V 32/3CP	475±15% / 36±15%	160/1600	W2.5x16d	E
13	T4W	AG029	T8.5 12V 4W	35±20%	500	BA9S	
14	C5W	AG030	10x31 12V 5W	45±20%	500	SV8.5	
	C5W	AG031	11x38 12V 5W	45±20%	500	SV8.5	
15	C10W	AG031-1	11x38 12V 10W	120±20%	250	SV8.5	
	C10W	AG032	11x44 12V 10W	120±20%	250	SV8.5	
16	RP35	AG033	RP 12V 35/35W	615±15% / 590±15%	200	P15D	

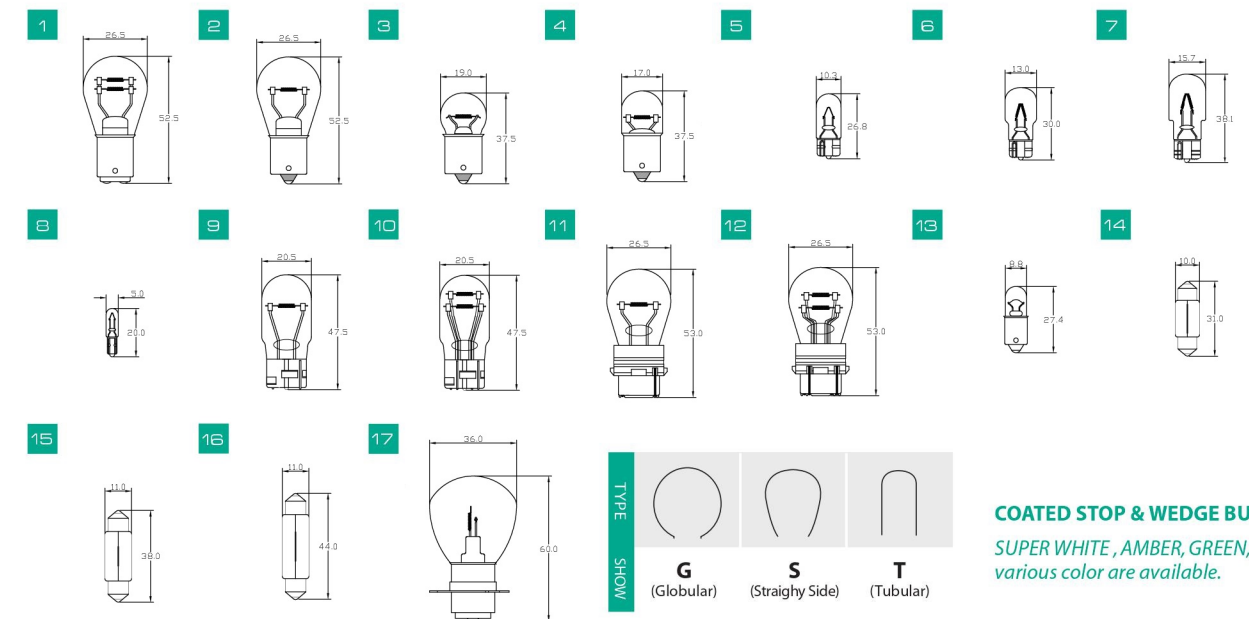

COATED STOP & WEDGE BULB-
SUPER WHITE, AMBER, GREEN, BLUE,
various color are available.

Packaging Design

H1 & H7 Replacement kit (8 pcs)



12.3x8x5.4cm

Type No. Spec.

AH1102

H1 12V 55W
H7 12V 55W
S25 BA15S 12V 21W
S25 BAY15D 12V 21/5W
T10 12V 5W
G18 BA15S 12V 5W
Plug in Fuse 10A
Plug in Fuse 15A

H1 Replacement kit (7 pcs)



11.2x6.5x5.4cm

Type No. Spec.

AH1103

H1 12V 55W
S25 BA15S 12V 21W
S25 BAY15D 12V 21/5W
T10 12V 5W
G18 BA15S 12V 5W
Plug in Fuse 10A
Plug in Fuse 15A

H4 Replacement kit (7 pcs)



11.2x6.5x5.4cm

Type No. Spec.

AH1104

H4 P43T 12V 60/55W
S25 BA15S 12V 21W
S25 BAY15D 12V 21/5W
T10 12V 5W
G18 BA15S 12V 5W
Plug in Fuse 10A
Plug in Fuse 15A

H7 Replacement kit (7 pcs)



11.2x6.5x5.4cm

Type No. Spec.

AH1105

H7 12V 55W
S25 BA15S 12V 21W
S25 BAY15D 12V 21/5W
T10 12V 5W
G18 BA15S 12V 5W
Plug in Fuse 10A
Plug in Fuse 15A

YB5-2A01



21.5x5x5.8cm

- 10 plastic cases/middle box
- 10 middle boxes/master carton
- 11/13KGS
- Master carton
- Dimension:72×33×45cm

YB5-2A



12x9.8x5.6cm

- 10 plastic cases/middle box
- 10 middle boxes/master carton
- 13/15KGS
- Master carton
- Dimension:72×33×45cm

YB5-3005



9x4.5x3.2cm

- 50 plastic cases/middle box
- 10 middle boxes/master carton
- 9/11KGS
- Master carton
- Dimension:72×33×45cm

YB5-3006



12.5x7.5x4.4cm

- 15 plastic cases/middle box
- 10 middle boxes/master carton
- 10/12KGS
- Master carton
- Dimension:72×33×45cm

Hanging Card



- 25 cards/middle box
- 10 middle boxes/master carton
- 10/12KGS
- Dimension:72x33x45cm

Hanging Card



- 25 cards/middle box
- 10 middle boxes/master carton
- 10/12KGS
- Dimension:72x33x45cm

Packaging Design

H1 (Au-lite/Xtec)



- 1pc/color box
- 100PCS/middle box
- 1000PCS/master carton
- 6.5/8KGS
- Dimension:x49x41x28cm

H3 (Au-lite/Xtec)



- 1pc/color box
- 100PCS/middle box
- 1000PCS/master carton
- 6.5/8KGS
- Dimension:49x41x28cm

H4 (Au-lite/Xtec)



- 1pc/color box
- 10 color boxes/shrinking
- 200PCS/master carton
- 4.6/7KGS
- Dimension:39x37x39cm

H7 (Au-lite/Xtec)



- 1pc/color box
- 10 color boxes/shrinking
- 500PCS/master carton
- 6/9KGS
- Dimension:39x37x39cm

9004 (Au-lite/Xtec)



- 1pc/color box
- 10 color boxes/shrinking
- 200PCS/master carton
- 4/7KGS
- Dimension:39x37x39cm

9005 (Au-lite/Xtec)



- 1pc/color box
- 10 color boxes/shrinking
- 200PCS/master carton
- 4/6.5KGS
- Dimension:39x37x39cm

9006 (Au-lite/Xtec)



- 1pc/color box
- 10 color boxes/shrinking
- 200PCS/master carton
- 4/6.5KGS
- Dimension:39x37x39cm

9007 (Au-lite/Xtec)



- 1pc/color box
- 10 color boxes/shrinking
- 200PCS/master carton
- 4/7KGS
- Dimension:39x37x39cm

G18 (Au-lite/Xtec)



- 10pc/color box
- 10 color boxes/middle box
- 10 middle boxes/carton
- 6/8KGS
- Dimension:60x25x21cm

S25 (Au-lite/Xtec)



- 10pc/color box
- 10 color boxes/middle box
- 10 middle boxes/carton
- 8/11KGS
- Dimension:75x30x26cm